

Rubidium Frequency Standard

AR133A

Ruggedized Low Profile

Key Features

- ❖ Long-term-stability: 5E-11/month
- ❖ 2E-12 frequency accuracy & 100nSec 1PPS accuracy relative to 1PPS input when disciplined (option)
- ❖ Short term stability: 5E-12 @ 100s
- ❖ Phase noise: -150dBc/Hz @ 10kHz
- ❖ Outputs: 10 MHz and 1PPS
- ❖ Supply voltage: 15 VDC / 12 VDC (option)
- ❖ Steady state power < 8W
- ❖ Power-saving mode – < 1.8W Steady State (option)
- ❖ Size: 77 x 77 x 25.4 mm (3" x 3" x 1")



Description

The AR133A is AccuBeat's new generation *multifunctional Rubidium Frequency Standard*. It is one of the smallest atomic standards available today, where the accuracy and stability are derived from a *quantum energy transition* that occurs in a *free rubidium atom*. The unit utilizes a unique advanced technology which allows a reduction of dimensions without sacrificing performance.

The AR133A is comprised of a unique *DPLL (Digital Frequency Lock Loop)* where a high performance crystal oscillator is locked to the rubidium atomic line using an embedded microprocessor and a special patented algorithm.

The algorithm optimizes the performance vs. external disturbances, improves temperature stability, enables very fine digital frequency control.

AR133A special modes of operation:

- **Disciplined to an external 1PPS (option):** This improves the long-term-stability and the accuracy and synchronize the phase of the 1PPS output to the 1PPS input.
- **Power-saving modes (options):** for applications where power is limited, the AR133A offers several power saving modes to be selected by the user.
 - **Mixed Mode (Option)** - in this mode, the Physics Package which is the main power consumer is turned on and off periodically therefore the average power consumption is much lower. When the Physics Package turn off the internal OCXO keeps supplying accurate frequency calibrated to the atomic clock frequency. Therefore the performance is a little less than Rubidium clock but better than OCXO with much more lower power consumption than Rubidium clock.
 - **OCXO Disciplined Mode (Option)** – this mode implements an OCXO disciplining to external 1PPS (with Physics Package shut-down) and consumes even a lower power of about 1.8 W

Applications

- | | | |
|------------------------|--------------------------|------------------------|
| ❖ Secure Communication | ❖ Telecommunication | ❖ TV Stations, HDTV |
| ❖ ELINT | ❖ Software Radio | ❖ Scientific Equipment |
| ❖ C4I | ❖ Test Equipment | ❖ Calibration |
| | ❖ Cellular Base Stations | |

STANDARD PRODUCT SPECIFICATIONS

Input & Outputs

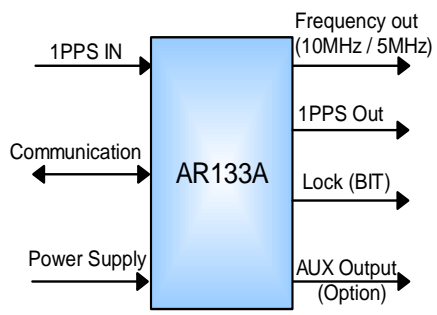
| | Standard | Option | |
|--|---|---|---|
| Outputs | - 10MHz sine wave +12±2 dBm into 50Ω - (*) In AR133A-01 output level is +7±2 dBm | - 5MHz instead of 10MHz - Square wave instead of sine wave |  |
| | 1PPS, 3V TTL into 50Ω Rise time < 30nSec Pulse width < 20uSec | | |
| AUX OUT: auxiliary frequency output in range 0Hz – 5MHz, like 1.544MHz (T1) and 2.048MHz (E1) – option For more information contact factory | | | |
| Input | 1PPS TTL 50Ω | | |
| Monitor & Control | RS-232 control and monitor interface provide: ID, Status, frequency adjustment. Protocol: 9600, 1, 8, 1, No parity | CMOS level | |
| | Digital frequency adjustment: 7.6E-13 steps over > 5E-7 range | | |

For more information about the communication channel contact factory.

Performance (Rubidium Mode)

| | | Standard | Option |
|---|-----------------------------------|--|---|
| Frequency | Short Term Stability | < 3E-11 @ 1s < 5E-12 @ 100s | |
| | Phase Noise | < -102 dBc/Hz @ 10Hz < -135 dBc/Hz @ 100Hz < -145 dBc/Hz @ 1kHz < -150 dBc/Hz @ 10kHz | |
| | Harmonics | < -44 dBc (up to 70MHz) | |
| | Spurious | < -80 dBc in the range 10Hz to 100kHz from carrier | |
| | Warm-up | < 5E-8 (Lock) within 4 minutes @ 25°C ±5E-10 within 5 minutes @ 25°C | |
| | Retrace | < 5E-11 with on-off-on cycle: 24 hours, 48 hours, 12 hours | |
| | Accuracy @ Shipment | < 5E-11 | |
| | Magnetic Field Sensitivity | < 8E-11 / gauss up to 3 gauss DC (worst direction) | |
| | Long Term Stability | < ±1E-9 / year (after 3 month operation) | < ±5E-10 / year (at shipment) Disciplined to external 1PPS - < ±2E-12 (24 hrs average) |
| Temperature Stability and Range | ±3E-10 over -20°C to +65°C | -40°C to +70°C | |
| Time Accuracy (1PPS) | Long-Term Accuracy | 1µs / 24 hours (after disciplining/calibration) | Disciplined to external 1PPS - 100ns (50ns typical.) RMS @ 25°C |
| Power Consumption (standard Rubidium mode) | | @ Steady-state | < 8W @ 25°C |
| | | @ Warm-up | < 18W @ 25°C |
| | | | < 14W @ 15VDC, room temp. (Time to Lock < 8 min) (**) |

(*) Unless specified, all parameters relate to 10MHz main output.

(**) Low Power at Warm Up (Option) - the internal ovens are activated in sequence thereby reducing the warm-up consumption.

Power Supply, Dimensions & Weight

| | |
|---------------|---------------------------------------|
| DC | 15±0.3 VDC / 12±0.3 VDC |
| Size | 77 mm x 77mm x 25.4 mm (3" x 3" x 1") |
| Weight | ≤ 295 g |

All specs are at room temperature, quiescent conditions, sea level ambient unless otherwise specified

BIT and Remote Control

Built In Test (BIT):

The built in test detects > 95% of all failures.
 Receive by hardware (pin number 3 in the D Type connector), open collector (10mA max).
 High impedance = BIT Fail; short to ground = BIT Pass & Lock.
 BIT result receives also by serial communication.

Mode of Operation

| | | |
|--------------------|---|---|
| Modes of Operation | Standard Rubidium Free-run | Standard |
| | Rubidium disciplining to Ext. 1PPS - Option | Excellent performance in Hold Over. |
| | OCXO disciplining to Ext. 1PPS - Option (*) | Medium performance in Hold Over. |
| | Mixed mode - Option (*) | Low average power consumption, good performance |

(*) For more information contact factory

Environmental

| | |
|-----------------------|--|
| Operating Temperature | -20°C to +65 °C (for wide temperature contact factory) |
| Storage Temperature | -40°C to +80°C |
| Humidity | Up to 95% at 35°C, non-condensed |

Mechanical & Electrical ICD

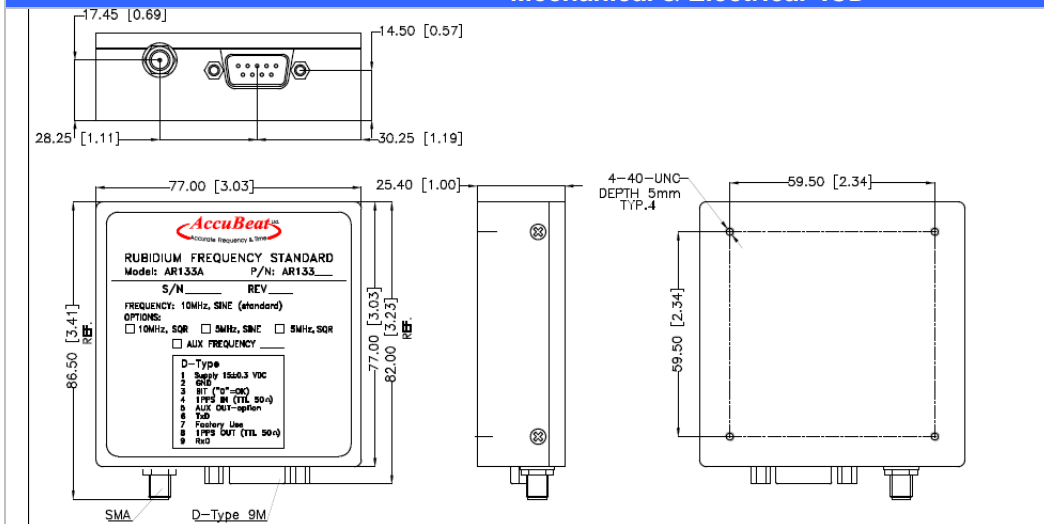

D-Type subminiature 9 pins (male):

- Pin 1 – Supply
- Pin 2 – GND
- Pin 3 – Lock (BIT)
- Pin 4 – 1PPS IN
- Pin 5 – AUX OUT - Option
- Pin 6 – TxD
- Pin 7 – Factory Use
- Pin 8 – 1PPS OUT
- Pin 9 – RxD

SMA: RF OUT

HOW TO ORDER

| Description | AccuBeat P/N | Note |
|------------------|--------------|--|
| Standard | AR13300 | Standard (15 VDC, 10MHz, Sine) |
| Low power | AR13301 | Mixed mode - Low average power consumption |
| 12V Input Option | AR13302 | 12 VDC, 10MHz, Sine |
| Improved ADEV | AR13303 | Improved Allan Deviation |